

# Installation Note

---

## Source Attenuators and Bias Tees Upgrade Kit

For E8361A/C PNA Series Microwave Network Analyzers

| Network Analyzer Model Number | Upgrade Kit Part Number |
|-------------------------------|-------------------------|
| E8361A/C                      | E8361-60104             |



**Agilent Technologies**

**Agilent Part Number: E8361-90005**

**Printed in USA May 2008**

Supersedes all previous printings.

© Agilent Technologies, Inc. 2003, 2005, 2007, 2008

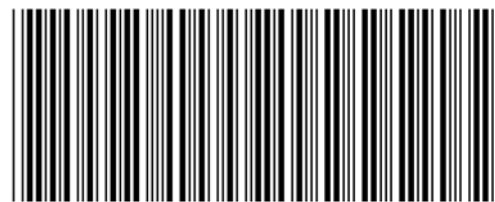

E8361-90005

---

## WARRANTY STATEMENT

THE MATERIAL CONTAINED IN THIS DOCUMENT IS PROVIDED “AS IS,” AND IS SUBJECT TO BEING CHANGED, WITHOUT NOTICE, IN FUTURE EDITIONS. FURTHER, TO THE MAXIMUM EXTENT PERMITTED BY APPLICABLE LAW, AGILENT DISCLAIMS ALL WARRANTIES, EITHER EXPRESS OR IMPLIED WITH REGARD TO THIS MANUAL AND ANY INFORMATION CONTAINED HEREIN, INCLUDING BUT NOT LIMITED TO THE IMPLIED WARRANTIES OF MERCHANTABILITY AND FITNESS FOR A PARTICULAR PURPOSE. AGILENT SHALL NOT BE LIABLE FOR ERRORS OR FOR INCIDENTAL OR CONSEQUENTIAL DAMAGES IN CONNECTION WITH THE FURNISHING, USE, OR PERFORMANCE OF THIS DOCUMENT OR ANY INFORMATION CONTAINED HEREIN. SHOULD AGILENT AND THE USER HAVE A SEPARATE WRITTEN AGREEMENT WITH WARRANTY TERMS COVERING THE MATERIAL IN THIS DOCUMENT THAT CONFLICT WITH THESE TERMS, THE WARRANTY TERMS IN THE SEPARATE AGREEMENT WILL CONTROL.

---

## DFARS/Restricted Rights Notice

If software is for use in the performance of a U.S. Government prime contract or subcontract, Software is delivered and licensed as “Commercial computer software” as defined in DFAR 252.227-7014 (June 1995), or as a “commercial item” as defined in FAR 2.101(a) or as “Restricted computer software” as defined in FAR 52.227-19 (June 1987) or any equivalent agency regulation or contract clause. Use, duplication or disclosure of Software is subject to Agilent Technologies’ standard commercial license terms, and non-DOD Departments and Agencies of the U.S. Government will receive no greater than Restricted Rights as defined in FAR 52.227-19(c)(1-2) (June 1987). U.S. Government users will receive no greater than Limited Rights as defined in FAR 52.227-14 (June 1987) or DFAR 252.227-7015 (b)(2) (November 1995), as applicable in any technical data.

---

## Safety Notes

The following safety notes are used throughout this document. Familiarize yourself with each of these notes and its meaning before performing any of the procedures in this document.

---

|                |   |
|----------------|---|
| <b>WARNING</b> | <b>Warning denotes a hazard. It calls attention to a procedure which, if not correctly performed or adhered to, could result in injury or loss of life. Do not proceed beyond a warning note until the indicated conditions are fully understood and met.</b> |
|----------------|---|

---

---

|                |   |
|----------------|---|
| <b>CAUTION</b> | Caution denotes a hazard. It calls attention to a procedure that, if not correctly performed or adhered to, could result in damage to or destruction of the instrument. Do not proceed beyond a caution sign until the indicated conditions are fully understood and met. |
|----------------|---|

---

---

## Contacting Agilent

Assistance with test and measurements needs and information on finding a local Agilent office are available on the Web at:

*www.agilent.com/find/assist*

If you do not have access to the Internet, please contact your Agilent field engineer.

---

**NOTE** In any correspondence or telephone conversation, refer to the Agilent product by its model number and full serial number. With this information, the Agilent representative can determine whether your product is still within its warranty period.

---

---

## About Installing the Upgrade Kit

---

**IMPORTANT** Option UNL can only be installed on analyzers with the option combinations listed below as “Products affected”. If your analyzer does not have the proper options (as listed below), it will be necessary to install those options BEFORE installing this option (Option UNL).

---

|  |  |
|--|--|
| Products affected . . . . .                      | E8361A/C with Option 014 (without Options 016 and 081)   |
| Installation to be performed by . . . . .        | Agilent service center or personnel qualified by Agilent |
| Estimated installation time . . . . .            | 2.0 hours  |
| Estimated adjustment time . . . . .              | 1.0 hours  |
| Estimated full instrument calibration time . . . | 4.5 hours  |

---

## Description of Option UNL

This option adds a 50-dB step attenuator and a bias tee between the source path switch and each of the front panel test ports.

The step attenuators are used to adjust the power level to the device under test (DUT) without changing the power in the reference path.

The bias tees provide a means of biasing active devices under test. DC bias for the bias tees is provided through two rear-panel BNC connectors. These inputs are fused for protection.

## Items Included in the Upgrade Kit

**NOTE** Check the contents of your kit against this list. If any item is missing or damaged, contact Agilent Technologies. Refer to “Contacting Agilent” on page 3.

**Table 1 Contents of Option UNL Upgrade Kit (E8361-60104)**

| Ref. Desig. | Description  | Qty | Part Number |
|-------------|--|-----|-------------|
|             | Installation note (this document)  | 1   | E8361-90005 |
|             | Front panel overlay  | 1   | E8361-80004 |
|             | Machine screw, M3.0 x 8 (for attaching attenuators and bias tees to brackets and for attaching brackets) | 16  | 0515-0372   |
|             | Machine screw, M3.0 x 25 (for attaching A23/A24 SOMA 70s to brackets)                                    | 8   | 0515-0667   |
|             | Bracket, A36/A37 attenuators and A38/A39 bias tees   | 2   | E8361-00003 |
|             | Bracket, A23/A24 SOMA 70s  | 2   | E8361-00002 |
| A36, A37    | 50-dB step attenuator  | 2   | 84905-60001 |
| A38, A39    | Bias tee   | 2   | 5086-7020   |
|             | Ribbon cable (for A36 step attenuator)   | 1   | 8121-0819   |
|             | Ribbon cable (for A37 step attenuator)   | 1   | 8121-0119   |
|             | Cable, 3-wire (for A38 and A39 bias tees)  | 2   | E7340-60075 |
| W3          | RF cable, A22 switch to A23 SOMA 70  | 1   | E8361-20003 |
| W20         | RF cable, A8 fractional-N synthesizer board J106 to A17 LOMA12 J2  | 1   | E8361-20046 |
| W21         | RF cable, A8 fractional-N synthesizer board J101 to A17 LOMA12 J3  | 1   | E8361-20045 |
| W51, W52    | RF cable, A23/A24 SOMA 70 to A36/A37 step attenuator   | 2   | E8361-20036 |
| W55         | RF cable, A38 bias tee to A25 test port 1 coupler  | 1   | E8361-20033 |
| W56         | RF cable, A39 bias tee to A26 test port 2 coupler  | 1   | E8361-20027 |
| W65         | RF cable, A23 SOMA 70 to REFERENCE 1 SOURCE OUT  | 1   | E8361-20015 |
| W66         | RF cable, A24 SOMA 70 to REFERENCE 2 SOURCE OUT  | 1   | E8361-20016 |
| W67, W68    | RF cable, A25/A26 test port coupler to PORT 1/PORT 2 CPLR ARM  | 2   | E8361-20018 |
| W69         | RF cable, PORT 1 RCVR A IN to A27 channel A mixer  | 1   | E8361-20066 |
| W70         | RF cable, REFERENCE 1 RCVR R1 IN to A28 channel R1 mixer   | 1   | E8361-20049 |
| W71         | RF cable, REFERENCE 2 RCVR R2 IN to A29 channel R2 mixer   | 1   | E8361-20020 |
| W72         | RF cable, PORT 2 RCVR B IN to A30 channel B mixer  | 1   | E8361-20048 |
| W81         | RF cable, A36 step attenuator to PORT 1 SOURCE OUT   | 1   | E8361-20035 |
| W82         | RF cable, A37 step attenuator to PORT 2 SOURCE OUT   | 1   | E8361-20026 |
| W83         | RF cable, PORT 1 CPLR THRU to A38 bias tee   | 1   | E8361-20034 |

**Table 1 Contents of Option UNL Upgrade Kit (E8361-60104)**

| <b>Ref. Desig.</b> | <b>Description</b>                         | <b>Qty</b> | <b>Part Number</b> |
|--------------------|--|------------|--------------------|
| W84                | RF cable, PORT 2 CPLR THRU to A39 bias tee | 1          | E8361-20028        |

---

## Installation Procedure for the Upgrade Kit

The network analyzer must be in proper working condition prior to installing this option. Any necessary repairs must be made before proceeding with this installation.

---

**WARNING**      **This installation requires the removal of the analyzer's protective outer covers. The analyzer must be powered down and disconnected from the mains supply before performing this procedure.**

---

### Electrostatic Discharge Protection

Protection against electrostatic discharge (ESD) is essential while removing or connecting cables or assemblies within the network analyzer.

Static electricity can build up on your body and can easily damage sensitive internal circuit elements when discharged. Static discharges too small to be felt can cause permanent damage. To prevent damage to the instrument:

- *always* wear a grounded wrist strap having a 1 M $\Omega$  resistor in series with it when handling components and assemblies.
- *always* use a grounded, conductive table mat while working on the instrument.
- *always* wear a heel strap when working in an area with a conductive floor. If you are uncertain about the conductivity of your floor, wear a heel strap.

Figure 1 shows a typical ESD protection setup using a grounded mat and wrist strap. Refer to "Tools and Equipment Required for the Installation" on page 8 for part numbers.

**Figure 1 ESD Protection Setup**

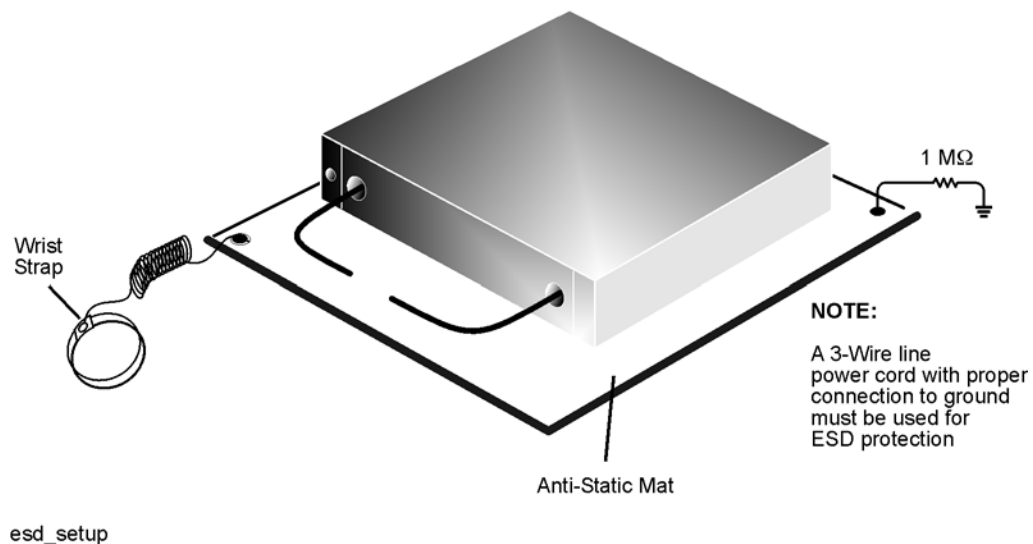

## **Overview of the Installation Procedure**

Step 1. Remove the Outer Cover.

Step 2. Replace (if necessary) Cables W20 and W21.

Step 3. Remove the Front Panel Assembly.

Step 4. Raise the Receiver Deck.

Step 5. Remove the Existing Cables.

Step 6. Replace the SOMA 70 Brackets (if necessary).

Step 7. Install the Attenuators, Bias Tees, and New Cables.

Step 8. Lower and Fasten the Receiver Deck and Connect the Bias Tee Control Cables.

Step 9. Replace the Lower Front Panel Overlay.

Step 10. Reinstall the Front Panel Assembly and Front Panel Jumpers.

Step 11. Reinstall the Outer Cover.

Step 12. Enable Option UNL.

Step 13. Perform Post-Upgrade Adjustments.

## Tools and Equipment Required for the Installation

| Description  | Agilent Part Number |
|--|---------------------|
| T-8 TORX driver (set to 5 in-lbs)                      | N/A                 |
| T-10 TORX driver (set to 9 in-lbs)                     | N/A                 |
| T-20 TORX driver (set to 21 in-lbs)                    | N/A                 |
| 5/16-inch torque wrench (set to 10 in-lbs)             | N/A                 |
| ESD grounding wrist strap                              | 9300-1367           |
| 5-ft grounding cord for wrist strap                    | 9300-0980           |
| 2 x 4 ft conductive table mat and 15-ft grounding wire | 9300-0797           |
| ESD heel strap (for use with conductive floors)        | 9300-1308           |



## Test Equipment Required for Post-Upgrade Adjustments

| Description   | Agilent Part Number |
|---|---------------------|
| Power meter   | E4418B/E4419B       |
| Power sensor, Type-N (100 kHz–4.2 GHz)  | 8482A               |
| Power sensor, 2.4 mm (4.2 GHz–50 GHz)   | 8487A               |
| Power sensor, V-Band (50 GHz–67 GHz) <sup>a</sup>   | V8486A              |
| Adapter, WR-15 to 1.85 mm (m) <sup>a</sup>  | V281B               |
| Adapter, 1.85 mm (f) to 1.85 mm (f) <sup>b</sup>  | 85058-60114         |
| Adapter, 2.4 mm (f) to 2.4 mm (f) <sup>b</sup>  | 11900B              |
| Adapter, Type-N (f) to 2.4 mm (f)   | 11903B              |
| Test cable, 2.4 mm (f) to 2.4 mm (f) <sup>b</sup> or<br>Test cable, 1.85 mm (f) to 1.85 mm (f) <sup>b</sup> | 85133C              |
|   | N4697E              |

- a. This sensor and adapter must be calibrated together by the Agilent factory. The data supplied are only valid as long as the sensor and adapter remain connected.
- b. The 1.85 mm connector has the same ruggedness and is compatible with the 2.4 mm connector. 1.85 mm and 2.4 mm connectors and adapters may be used interchangeably.

## Step 1. Remove the Outer Cover

**CAUTION** This procedure is best performed with the analyzer resting on its front handles in the vertical position. *Do not place the analyzer on its front panel without the handles.* This will damage the front panel assemblies.

Refer to Figure 2.

1. Disconnect the power cord (if it has not already been disconnected).
2. With a T-20 TORX driver, remove the strap handles (item ④) by loosening the screws (item ⑤) on both ends until the handle is free of the analyzer.
3. With a T-20 TORX driver, remove the four rear panel feet (item ①) by removing the center screws (item ②).
4. Slide the four bottom feet (item ③) off the cover.
5. Slide the cover off of the frame.

**Figure 2 Outer Cover Removal**

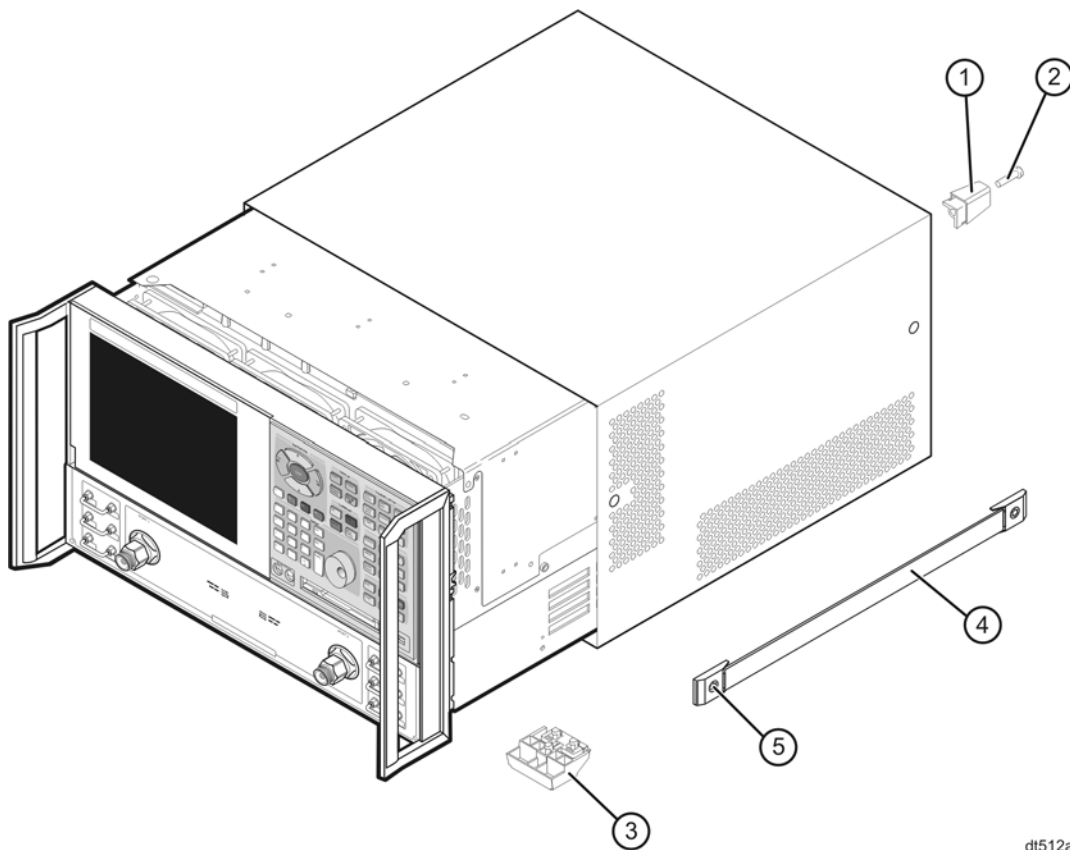

dt512a

---

**NOTE**

The previous figure shows the E8361A front panel and floppy disk drive. The E8361A front panel has a slightly different appearance and does not include a floppy disk drive.

---

## Step 2. Replace (if necessary) Cables W20 and W21

Refer to Figure 3 and Figure 4.

1. Place the analyzer top-side up.
2. With a T-10 TORX driver, remove the 11 screws (item ①) used to attach the inner cover and lift off the inner cover.
3. Examine the part number labels on cables W20 (connected to A8J106) and W21 (connected to A8J101).
  - If the part numbers are E8361-20045 and E8361-20046 respectively, then they do not need to be replaced. Proceed to step 5 on the next page.
  - If the part numbers ARE NOT E8361-20045 and E8361-20046 respectively, they need to be replaced. Proceed to step 4 on the next page.

**Figure 3 Inner Cover Removal to Verify W20 and W21 Part Numbers**

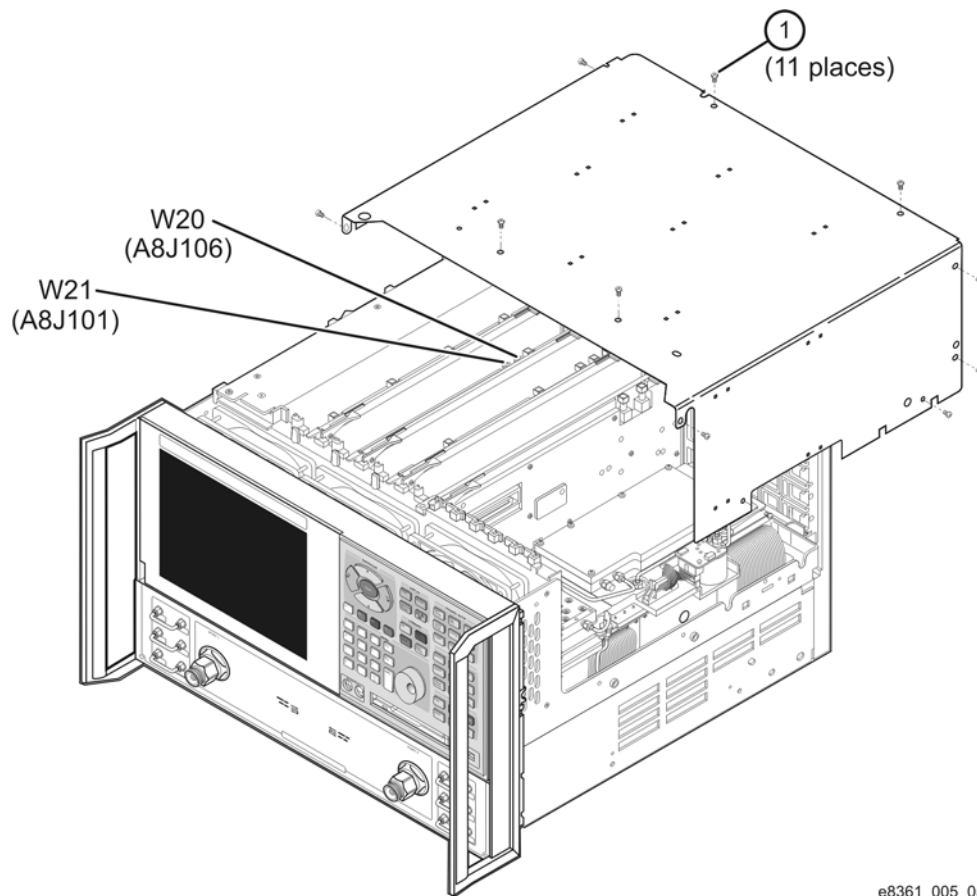

e8361\_005\_05

---

**NOTE** The figure above shows the E8361A front panel and floppy disk drive. The E8361A front panel has a slightly different appearance and does not include a floppy disk drive.

---

4. To replace cables W20 and W21:
  - a. Place the analyzer on its side as shown in Figure 4.
  - b. Remove the cable hold-down wire (item ②).
  - c. Disconnect cables W20 and W21 at both ends; two top side connections and two bottom side connections. Remove the cables from the analyzer.
  - d. Position the new cables in the analyzer and connect them as follows: W20–A8J106 to A17J2; W21–A8J101 to A17J3. Tighten the connectors to 10 in-lbs.
  - e. Reinstall the cable hold-down wire (item ②).

**Figure 4 Replacing Cables W20 and W21**

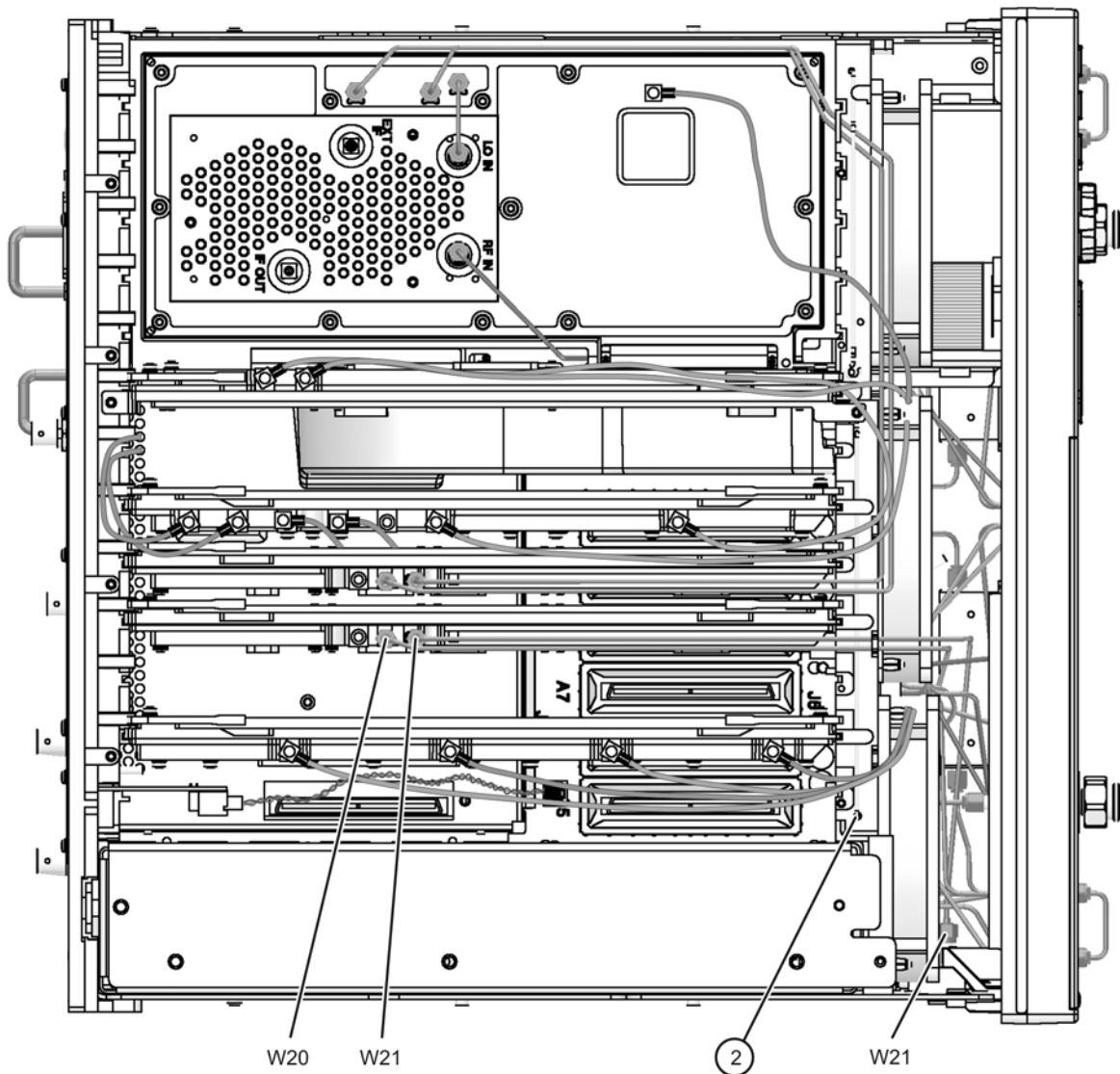

e8361\_005\_07

5. Replace the inner cover by reinstalling the 11 attachment screws (item ①).

### Step 3. Remove the Front Panel Assembly

Refer to Figure 5.

1. With a 5/16-inch wrench, remove the six front panel semirigid jumper cables (item ①).
2. With a T-10 TORX driver, remove the eight screws (item ②) from the sides of the frame.

---

**CAUTION** Before removing the front panel from the analyzer, lift and support the front of the analyzer chassis.

---

3. Slide the front panel over the test port connectors.
4. Disconnect the front panel interface ribbon cable (item ③) from the A3 front panel interface board. The front panel is now free from the analyzer.

**Figure 5 Front Panel Assembly Removal**

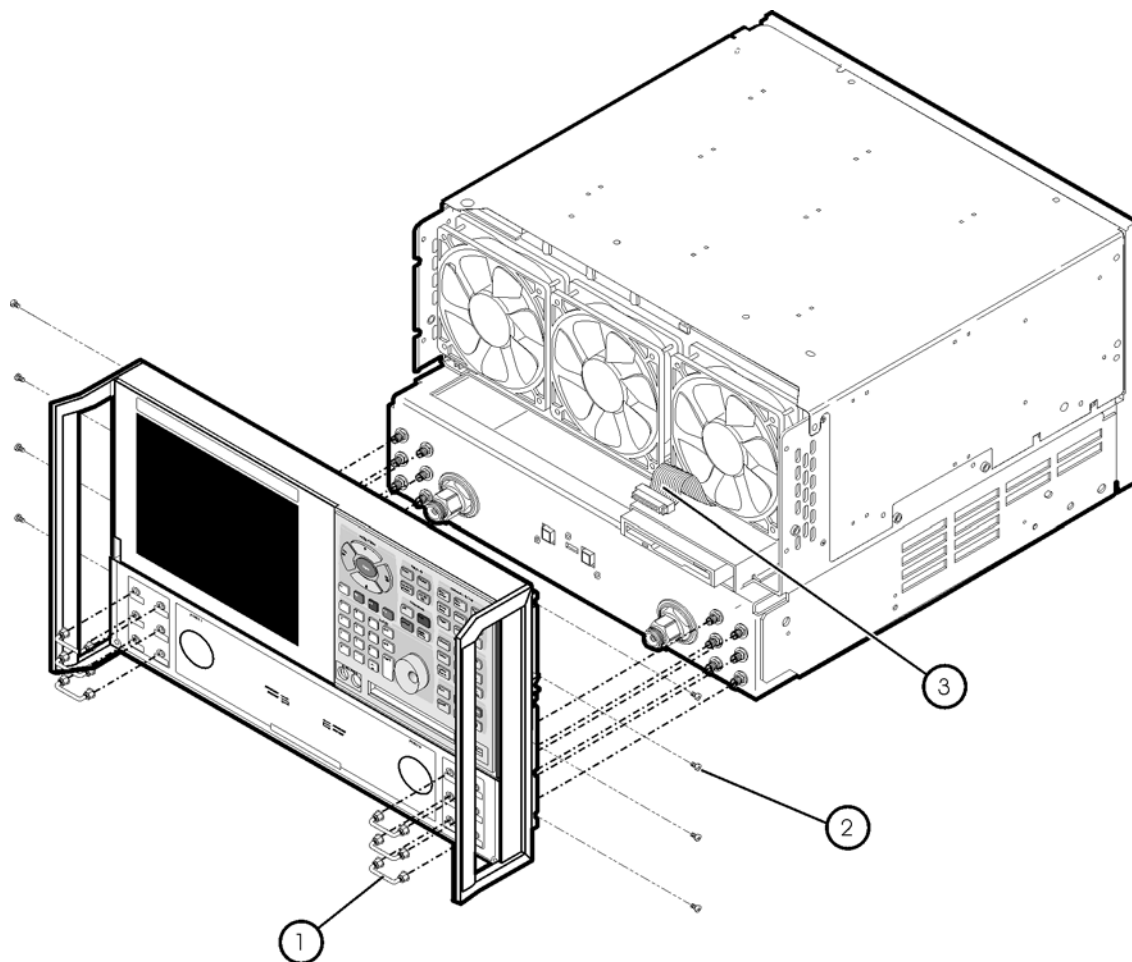

st536a

---

**NOTE**

The previous figure shows the E8361A front panel and floppy disk drive. The E8361A front panel has a slightly different appearance and does not include a floppy disk drive.

---

## Step 4. Raise the Receiver Deck

Refer to Figure 6.

1. Place the analyzer bottom-side up on a flat surface.
2. With a T-10 TORX driver, remove the four screws, (item ①), that secure the receiver deck.
3. Pull the latch pin (item ②) towards the opposite side of the analyzer to release the receiver deck.
4. Lift the receiver deck to partially raise it, then release the latch pin (item ②). Lift the receiver deck to its fully raised position and ensure that the latch pin latches in the raised position.

**Figure 6 Receiver Deck Raising**

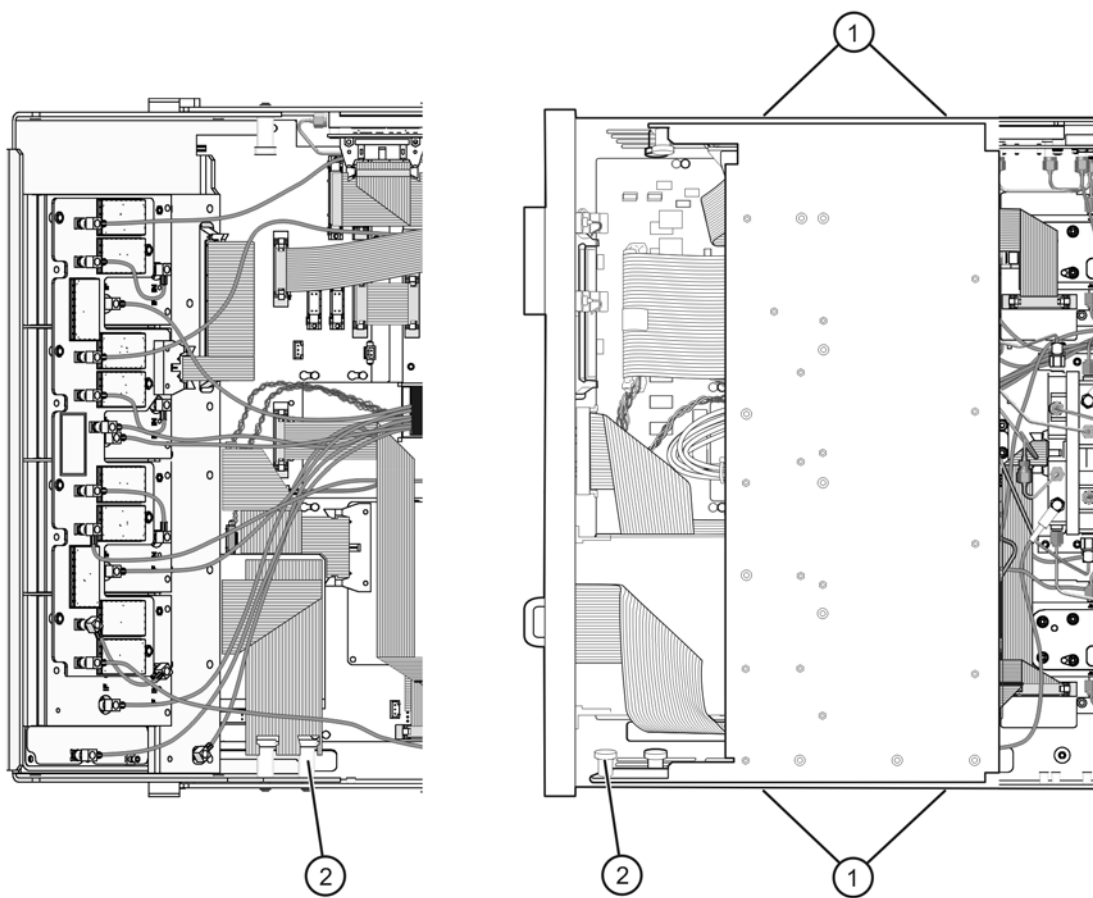

8364\_022\_16



## Step 5. Remove the Existing Cables

Refer to Figure 7.

Remove the following cables. These cables will be replaced later.

- W3 A22 switch to A23 SOMA 70
- W65 A23 SOMA 70 to REFERENCE 1 SOURCE OUT
- W63 PORT 1 CPLR THRU to A25 test port 1 coupler
- W61 A23 SOMA 70 to PORT 1 SOURCE OUT
- W69 PORT 1 RCVR A IN to A27 channel A mixer
- W67 A25 test port 1 coupler to PORT 1 CPLR ARM
- W66 A24 SOMA 70 to REFERENCE 2 SOURCE OUT
- W64 PORT 2 CPLR THRU to A26 test port 2 coupler
- W62 A24 SOMA 70 to PORT 2 SOURCE OUT
- W72 PORT 2 RCVR B IN to A30 channel B mixer
- W68 A26 test port 2 coupler to PORT 2 CPLR ARM
- W70 REFERENCE 1 RCVR R1 IN to A28 channel R1 mixer
- W71 REFERENCE 2 RCVR R2 IN to A29 channel R2 mixer

**Figure 7 Existing Cables Removal and Replacement**

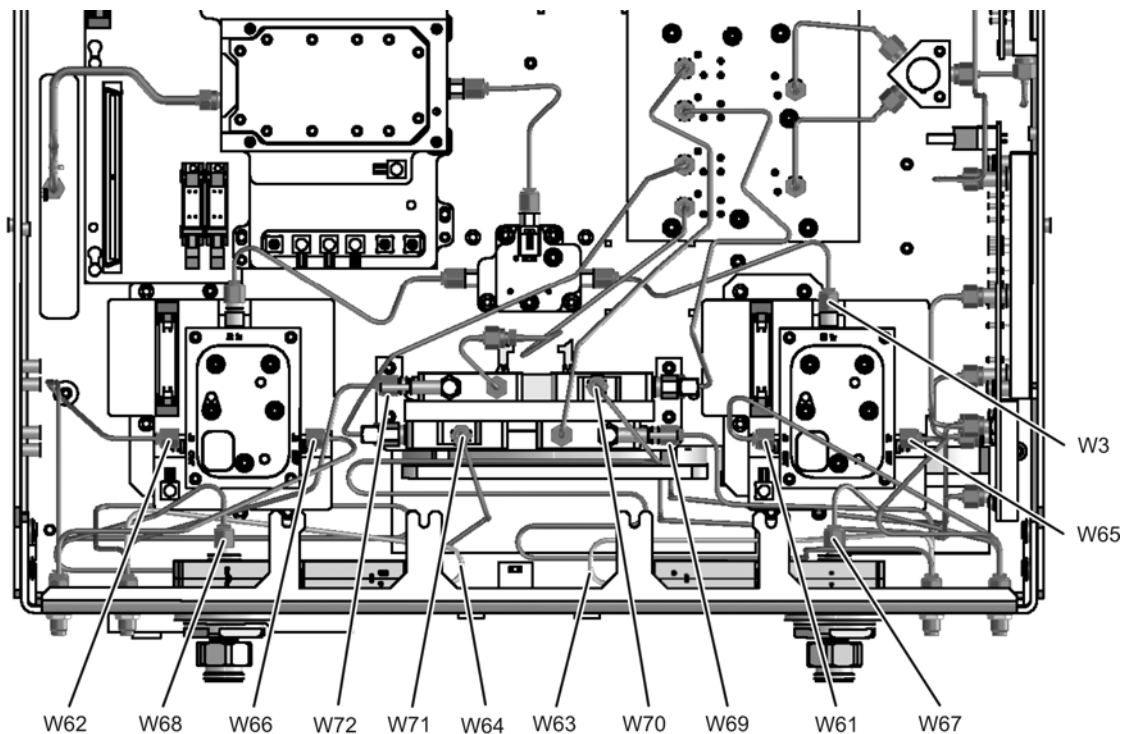

e8361\_005\_01

## Step 6. Replace the SOMA 70 Brackets (if necessary)

Refer to Figure 8.

1. Examine the SOMA 70 brackets, as identified, to determine their shape.
  - If your analyzer has the *new* brackets, then they do not need to be replaced. Proceed to step 7 on the next page.
  - If your analyzer has the *old* brackets, then they will have to be replaced with the new brackets provided before proceeding. Continue with step 2 on this page.
2. Disconnect cable W4. All cables should now be disconnected from the SOMA 70s.
3. Remove the A23 and A24 SOMA 70s from their brackets by removing four screws (item ①) from each. Discard these eight screws, new ones of a different length are provided.
4. Remove the SOMA 70 brackets by removing three screws (item ②) from each bracket.
5. Install the new brackets using the screws (item ②) removed from the old brackets.
6. Install the A23 and A24 SOMA 70s on the new brackets using four new screws (item ①) each, provided in the kit.
7. Reconnect cable W4 and install the new cable W3, provided in the kit.

**Figure 8 SOMA 70 Brackets Replacement**

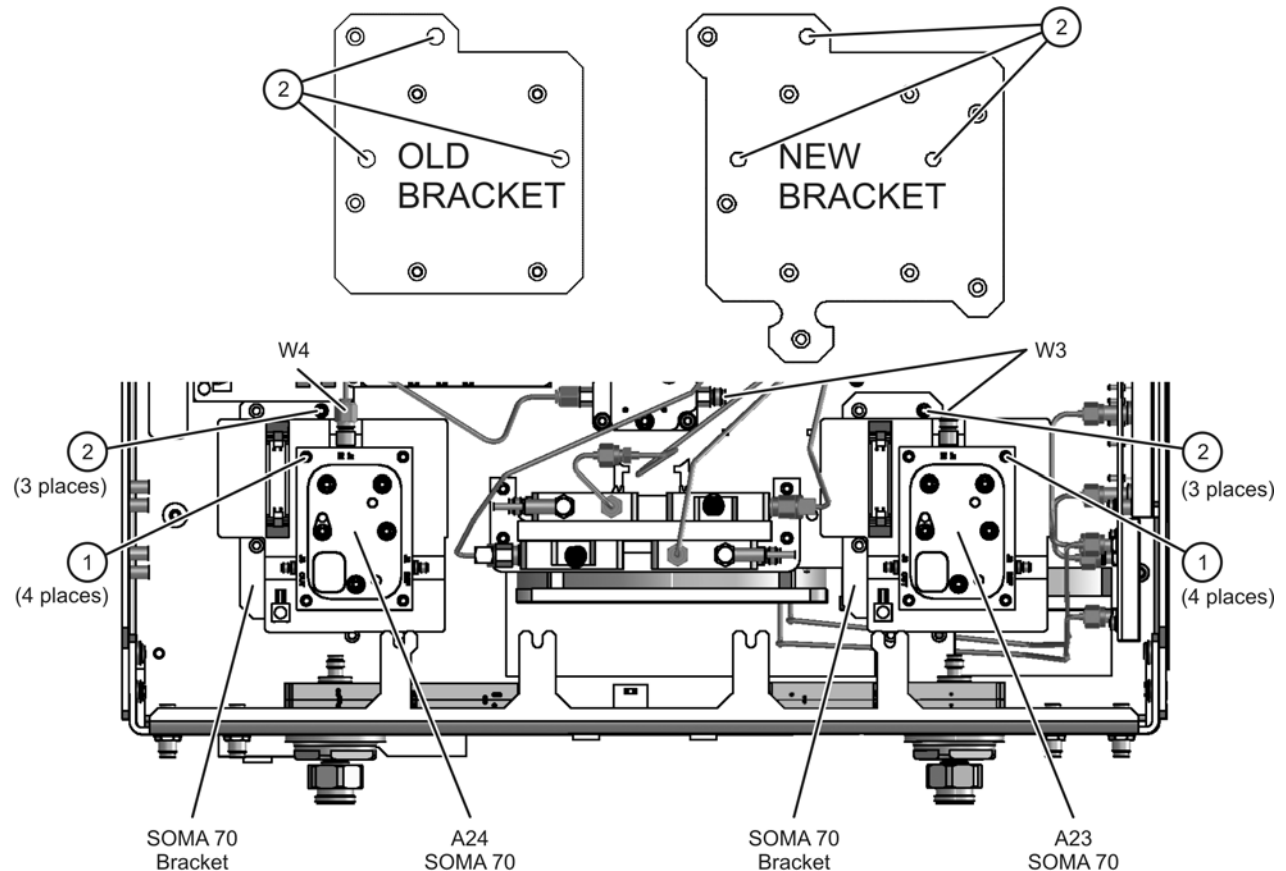

e8361\_005\_06

## Step 7. Install the Attenuators, Bias Tees, and New Cables

### Install the Attenuators and Bias Tees on the Brackets

Refer to Figure 9.

The attenuators and bias tees must first be attached to their mounting brackets.

1. Attach a step attenuator to each bracket using two screws (item ①) provided for each. Be sure to orient the attenuators as shown.
2. Attach a bias tee to each bracket using two screws (item ②) provided for each. Be sure to orient the bias tees as shown.

**Figure 9 Attenuator and Bias Tee Installation on Bracket**

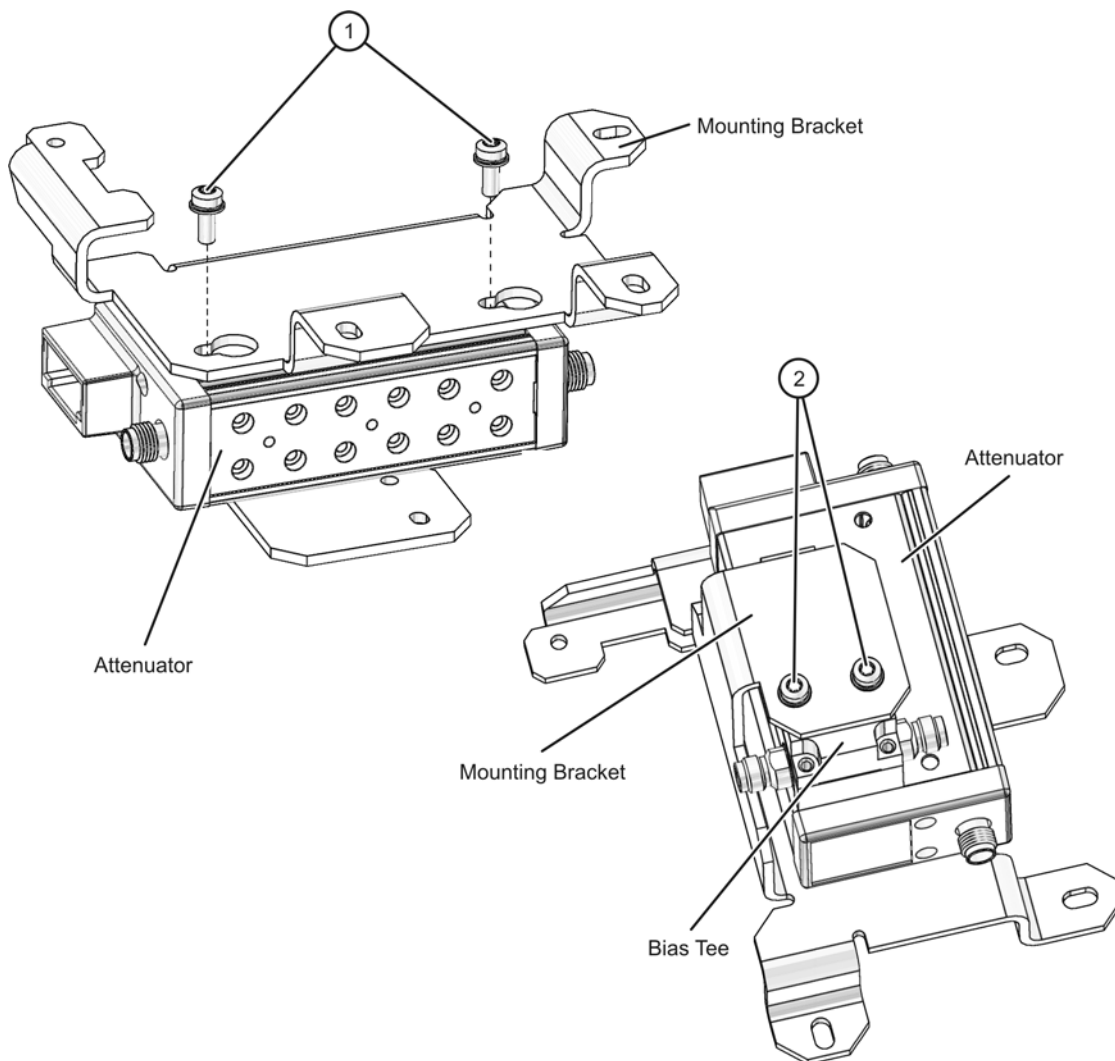

e8361\_005\_02

## Install the Brackets and the Option UNL Cables in the Analyzer

Refer to Figure 10.

1. Place the brackets (item ①) in the analyzer, with the step attenuators and bias tees attached. Secure the brackets using four screws (item ②) provided for each.
2. Connect the bias tee control cables (item ③) to the A38 and A39 bias tees and route them through the cable clamp, (item ④), to the rear of the analyzer for connection to the A16 motherboard later.
3. Install the following cables in the order listed. Make sure to use the cables provided in the kit, even for cables with identical part numbers. Do not reuse the old cables.
  - Ribbon cable ⑤ 8121-0819 A36 step attenuator to A16 motherboard (P1 SRC ATT)
  - Ribbon cable ⑥ 8121-0119 A37 step attenuator to A16 motherboard (P2 SRC ATT)
  - W51 E8361-20036 A23 SOMA 70 to A36 step attenuator
  - W52 E8361-20036 A24 SOMA 70 to A37 step attenuator
  - W71 E8361-20020 REFERENCE 2 RCVR R2 IN to A29 channel R2 mixer
  - W70 E8361-20049 REFERENCE 1 RCVR R1 IN to A28 channel R1 mixer
  - W67 E8361-20018 A25 test port 1 coupler to PORT 1 CPLR ARM
  - W68 E8361-20018 A26 test port 2 coupler to PORT 2 CPLR ARM
  - W72 E8361-20048 PORT 2 RCVR B IN to A30 channel B mixer
  - W82 E8361-20026 A37 step attenuator to PORT 2 SOURCE OUT
  - W84 E8361-20028 PORT 2 CPLR THRU to A39 bias tee
  - W66 E8361-20016 A24 SOMA 70 to REFERENCE 2 SOURCE OUT
  - W69 E8361-20066 PORT 1 RCVR A IN to A27 channel A mixer
  - W83 E8361-20034 PORT 1 CPLR THRU to A38 bias tee
  - W81 E8361-20035 A36 step attenuator to PORT 1 SOURCE OUT
  - W65 E8361-20015 A23 SOMA 70 to REFERENCE 1 SOURCE OUT
  - W56 E8361-20027 A39 bias tee to A26 test port 2 coupler
  - W55 E8361-20033 A38 bias tee to A25 test port 1 coupler



## Step 8. Lower and Fasten the Receiver Deck and Connect the Bias Tee Control Cables

Refer to Figure 11.

1. Pull the latch pin (item ②) toward the center of the analyzer to release the receiver deck.
2. Lift the receiver deck to partially lower it, then release the latch pin (item ②). Lower the receiver deck to its fully lowered position and ensure that the latch pin latches in the lowered position.
3. With a T-10 TORX driver, install the four screws (item ①) to secure the receiver deck.
4. Connect the bias tee cables to the A16 motherboard connectors as indicated.
5. The dc bias input connectors and fuse holders (fuses included) are already installed on the rear panel but covered. Using a T-10 TORX driver, remove the four screws from the cover and remove and discard the cover.

**Figure 11 Receiver Deck Lowering**

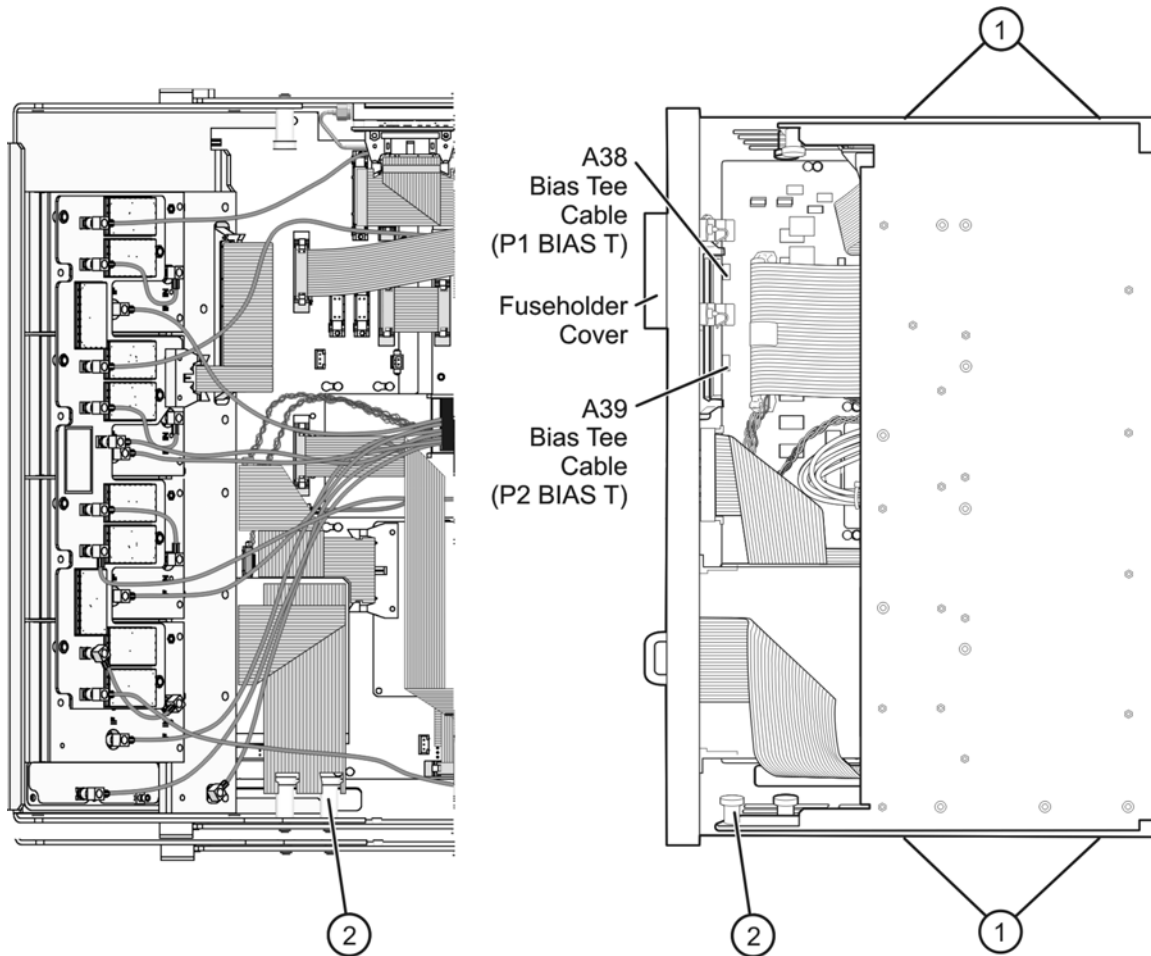

e8361\_005\_04

## Step 9. Replace the Lower Front Panel Overlay

Refer to Figure 12 for this procedure.

1. From the back side of the front panel, use a blunt object in one of the cutouts in the frame to push the overlay (item ①) and separate it from the front panel.
2. From the front side of the front panel, pull the overlay completely off and discard it.
3. Remove any adhesive remaining on the front panel.
4. Remove the protective backing from the new front panel overlay (item ①).
5. Starting from either the left or right side, *loosely* place the overlay in the recess on the lower front panel, ensuring that it fits tightly against the recess edges.
6. Once the overlay is in place, press it firmly onto the frame to secure it.

**Figure 12 Lower Front Panel Overlay Replacement**

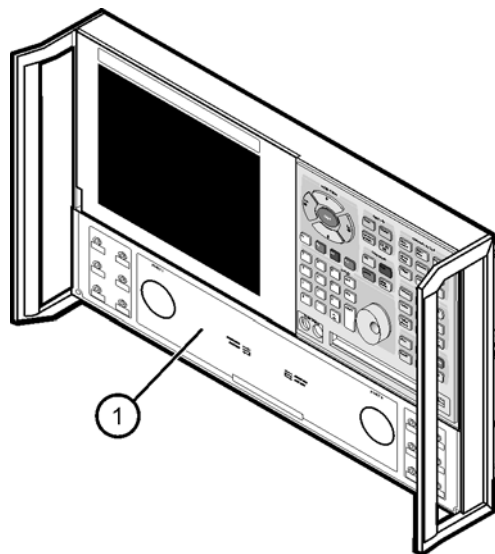

dt510a

---

**NOTE** The figure above shows the E8361A front panel and floppy disk drive. The E8361A front panel has a slightly different appearance and does not include a floppy disk drive.

---

## Step 10. Reinstall the Front Panel Assembly and Front Panel Jumpers

**CAUTION** Before installing the front panel assembly onto the analyzer, lift and support the front of the analyzer chassis.

Refer to Figure 13.

1. Tighten all 12 of the front-panel feed-through connectors using a 5/16-inch torque wrench set to 21-inch lbs.
2. Reconnect the ribbon cable (item ③) to the A3 front panel interface board.
3. Slide the front panel over the test port connectors being careful to align the power switch and floppy disk drive to their corresponding front panel cutouts. Ensure that the ribbon cable (item ③) is located below the fan to prevent it from being damaged by the fan blades.
4. With a T-10 TORX driver, install the eight screws (item ②) in the sides of the frame.
5. Install the six semirigid jumpers (item ①) on the front panel and tighten to 10-inch lbs.

**Figure 13 Front Panel Assembly Reinstallation**

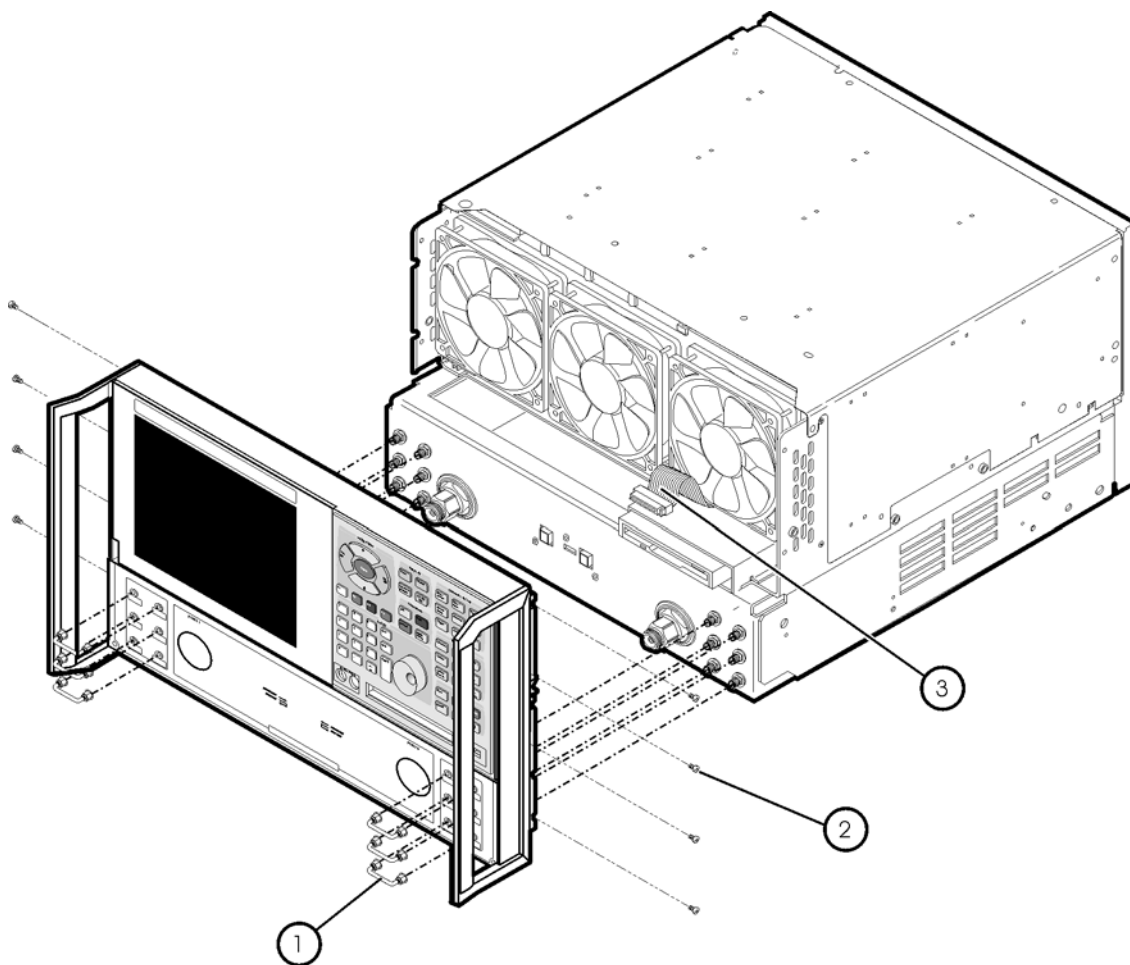

st536a



---

**NOTE**

The previous figure shows the E8361A front panel and floppy disk drive. The E8361A front panel has a slightly different appearance and does not include a floppy disk drive.

---

## Step 11. Reinstall the Outer Cover

---

**CAUTION** This procedure is best performed with the analyzer resting on its front handles in the vertical position. *Do not place the analyzer on its front panel without the handles.* This will damage the front panel assemblies.

---

Refer to Figure 14 for this procedure.

1. Slide the cover over the analyzer frame.
2. With a T-20 TORX driver, install the four rear panel feet (item ①) by installing the center screws (item ②).
3. Slide the four bottom feet (item ③) into position on the cover.
4. With a T-20 TORX driver, install the strap handles (item ④) by installing the screws (item x) on both ends of the handles.

**Figure 14 Outer Cover Reinstallation**

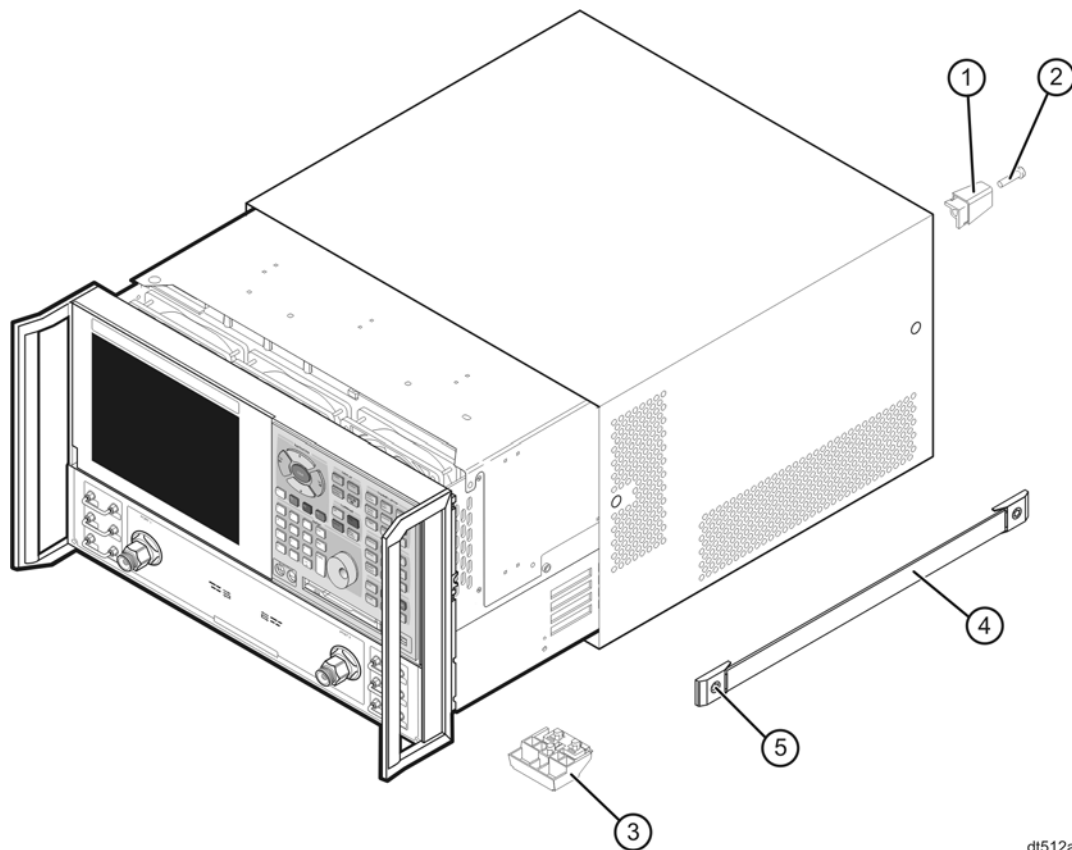

dt512a

---

**NOTE** The figure above shows the E8361A front panel and floppy disk drive. The E8361A front panel has a slightly different appearance and does not include a floppy disk drive.

---

## Step 12. Enable Option UNL

### Procedure Requirements

- The analyzer must be powered up and operating to perform this procedure.
- The Network Analyzer program must be running.
- A mouse is recommended for this procedure but is not required.

### Enable Option UNL

1. On the analyzer's **System** menu, point to **Service**, and then click **Option Enable**.
2. In the **Select Desired Option** list, click **UNL - Bias Tees w/Atten**.
3. Click **Enable**.
4. Click **Yes** in answer to the displayed question in the **Restart Analyzer?** box.
5. When the installation is complete, click **Exit**.

### Verify that Option UNL is Enabled

1. On the analyzer's **Help** menu, click **About Network Analyzer**.
2. Verify that "UNL" is listed after "Options:" in the display. Click **OK**.

---

**NOTE** If Option UNL has not been enabled, perform this step again. If the option is still not enabled, contact Agilent Technologies. Refer to "Contacting Agilent" on page 3.

---

## Step 13. Perform Post-Upgrade Adjustments

The following adjustments must be made due to the hardware changes made to the analyzer.

- source calibration
- phase lock IF gain adjustment
- receiver calibration

These adjustments are described in the PNA service guide and in the PNA on-line HELP. A list of equipment required to perform these adjustments can be found at “Test Equipment Required for Post-Upgrade Adjustments” on page 9.

### Performance Tests and System Verification

The analyzer should now operate and phase lock over its entire frequency range.

---

**NOTE** If you experience difficulty with the basic functioning of the analyzer, contact Agilent. Refer to “Contacting Agilent” on page 3.

---

Although the analyzer functions, its performance relative to its specifications has not been verified.

It is recommended that a full instrument calibration be performed using the PNA performance test software.

If the testing of the analyzer’s full range of specifications is not required, a system verification can be performed.

Refer to the analyzer’s service guide for information on performance tests and system verification.